

# Beehive Fence Construction Manual

A step by step guide to building a protective beehive fence to deter crop-raiding elephants from farm land

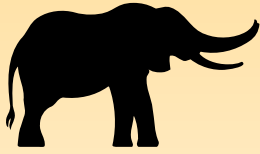

Written and Illustrated by Dr Lucy E. King

Save the Elephants and University of Oxford  
Funded by Disney Worldwide Conservation Fund &  
The St Andrews Prize for the Environment



[www.elephantsandbees.com](http://www.elephantsandbees.com)

Front cover images: (1) Elephant family walking to waterhole in Tsavo East National Park; (2) Beehive fence protecting a maize field in Sagalla community, next to Tsavo East National Park; (3) Farmers harvesting pure honey from a KTBH beehive fence, Etorro, Ngare Mara, Isiolo; (4) Turkana farmers constructing a beehive fence in Etorro community, Ngare Mara, Isiolo.

Photo credits: Dr Lucy E. King

Copyright © Dr Lucy E. King

Third Edition 2014

All rights reserved

Published by

The Elephants and Bees Project

Save the Elephants

P.O. Box 54667

Nairobi 00200

Kenya

Project website: [www.elephantsandbees.com](http://www.elephantsandbees.com)

Email: [lucy@savetheelephants.org](mailto:lucy@savetheelephants.org)

# Beehive Fence Construction Manual

Contents	Page
Introduction	1
Elephant behaviour and human-elephant conflict	2
Traditional, KTBH or Langstroth beehives?	3
Beehive fences using traditional log beehives	4
Beehive fences using Kenyan top bar hives	5
Step by step construction of Kenyan top bar hives	6-8
Beehive fences using Langstroth beehives	9
Constructing the beehive fence	10-11
Using “dummy hives” in your beehive fence	12
Common issues and maintenance tips	13
Harvesting Honey	14
Hive occupation records	15
Elephant movement records	16
Predicted conditions of success	17
The science behind the manual	18
Save the Elephants Organisation	19
Biography, Author’s note and Acknowledgements	20



# Beehive Fence Construction Manual



Written and Illustrated by Dr Lucy E. King

## Introduction

Elephants in Kenya are not confined to national parks and reserves hence interactions with farmers, and specifically crop raiding by elephants, pose serious social, political, economic and conservation problems in Kenya as it does in many other parts of Africa. Accordingly, research efforts are now focused on finding effective farmer-managed deterrents that are both socially and economically suitable especially in 'conflict' zones where effective electric fences to separate humans from elephants are neither feasible nor affordable. This *Beehive Fence Construction Manual* is the output of collaborative applied research by The Elephants and Bees Project at Save the Elephants, in partnership with Oxford University and Disney's Animal Kingdom investigating the use of bees as a natural deterrent for crop raiding elephants.

## Elephants avoid Bees



Playback methods conducted with known elephants in Samburu and Buffalo Springs National Reserves in Kenya have revealed that elephants will run from the sound of disturbed honey bees. Additionally, when they

do run away, the elephants also emit a unique low frequency "bee alarm rumble" vocalization which warns neighbouring elephants to retreat as well. These behavioural discoveries have revealed that elephants appear to retain a negative memory about honey bees which 'scares' them away from an area. Anecdotes from local people, who have witnessed elephants being stung by swarms of bees, tell us that elephants can be stung around the eyes, up the trunk and behind the thinner skin of the ears which must be painful enough to make them wary of future encounters with the insects.

With assistance from The Elephants and Bees Project, rural farmers are using this knowledge to protect their fields from crop raiding elephants. They are building beehive fences of strong posts round their vegetable fields on which they hang

beehives at regular 10 meter spaces. Trial beehive fences have now been built around dozens of farms in Kenya. This research has involved monitoring the effect of the beehive fences on deterring crop-raiding elephants as well as understanding how farmers adapt to the new technology. To date the beehive fences have been extremely successful in stopping elephants from breaking through to enter the farms. Farmers keep their fences and beehives in good order as they can make a lot of money from selling the honey. The participating farmers are benefiting from this "Elephant-Friendly Honey" and awareness and tolerance for elephants is slowly increasing. This manual is intended to encourage farmers and wildlife managers across Africa to manage human-elephant conflict in a new, sustainable and beneficial way.



Elephant-Friendly Honey

# Elephant Behaviour and Human-Elephant Conflict

The African elephant is perhaps the most iconic migratory land mammal on the continent. Catastrophic poaching in the 1970's and 80's saw their populations plummet to a mere fraction of pre 1970's numbers. An effective international ivory trade ban implemented by CITES in 1989 combined with improved wildlife management strategies, has resulted in rising numbers, particularly in East and Southern Africa. However, these elephants are expanding into a world now densely settled by people. Rising incidents of human-elephant conflict are occurring where elephants are exploring old migratory routes and either being blocked by new developments or breaking into farmland plots to take advantage of nutritional agricultural produce. Elephants tend to crop-raid at night time, and farmers confronting elephants in the dark are often left with no choice but to throw stones and fire crackers or shoot bullets into the air to try to scare them away. This confrontation leads to heightened aggression and some elephants will charge and attack. These negative incidents often lead to terrible injuries or deaths of both people and elephants.



## Natural Migration

Elephants are herbivores and hence have no reason to attack man unless its in self defense. Females travel in family groups with the young protected and guided by the older females and matriarch. Teenage bulls tend to leave their families and join up with older bull elephants where they learn how to find seasonal water and food. As these elephants migrate through the landscape looking for food and water they will take advantage of any juicy crops they come across. Keeping key migration corridors open and clear of farms and development will reduce the chance of conflict incidents developing. Beehive fences are designed to protect individual farms so that elephants can walk around and continue on their migration routes.



## The loss of key individual elephants

Unfortunately both people and elephants are sometimes killed due to conflict over resources. Elephants that are wounded are often very dangerous and can go wild with pain which poses a great threat to anyone in their path. Fatal wounds resulting in the death of an elephant is not only illegal, and should be avoided at all costs, but also causes stress within the family unit. Elephants have long memories and there is some evidence that elephants who have lost a family member due to conflict or culling may become more aggressive to humans in the future.



## Barriers to conflict

Ideally it is best to stop elephants from entering a farm as, once they are inside and feasting on crops, it is almost impossible to chase them away safely. Farm barriers include wooden fences, thorn brush, hedges, chilli oil covered ropes, cow bells and stone walls. Electric fences can be good deterrents but are often too expensive for most rural famers to install. Usually a combination of barriers and deterrents is a good idea. In this manual we describe how to construct beehive fence barriers around individual farms but combining multiple elephant deterrent should also be tried.

# Traditional, KTBH or Langstroth Hives?

Beehive fences erected to stop elephants from entering individual farms can be made with any type of beehive. If you already own or are using beehives on your farm it is very cheap and easy to convert your existing beekeeping project into a protective beehive fence. Strip bark hives, log hives, basket hives even old tin trunks can be hung from posts to create a beehive fence. Essential to all hives is some kind of shade to keep the bees cool and easy access to harvest honey, but other than those two stipulations, feel free to adapt the resources you have. Below the table summarises my experiences and suggestions for the uses of three beehives and enables you to make your own decision on what beehives to use.

	Traditional Log Hives	Kenyan Top Bar Hives (KTBH)	Langstroth Beehives
Cost	Much cheaper, free if made from hollowed out tree trunks. Often present in communities and simply need to be moved into a linear fence structure to become effective crop protectors.	More expensive to make as materials like plywood, cedar top bars, nails and varnish need to be bought. With economies of scale, expect to pay roughly \$35 a hive for materials.	Most expensive of the beehives and usually bought from professional honey companies. Expect to pay roughly \$60 a hive which should include one super box.
Construction	Simple hive end covers need to be made to close off the entrances to the hive leaving just a small gap for the bees to enter.	Construction needs more effort compared to the use of traditional log hives but if our design is followed one man can make 3 hives in a day.	Intricate and complex. Designed to have a separate super box stacked above the brood chamber. Both contain moulded wax strips fitted into framed top bars.
Harvesting ease	Not so easy to harvest as access to the hive is only from one direction (the entrance). There is no way to stop the bees from all swarming out into the harvester so bee stings can be more common.	Easy to harvest as one top bar is lifted out and harvested at a time. Honey comb comes out in natural, attractive curved shapes that match the shape of the beehive. Usually the comb is cut off the top bar.	Very easy to harvest, honey can be spun out of the combs and the wax foundations are replaced into hive for quick re-colonisation. Once a hive is strong, frequent honey harvesting is possible.
Honey quality and quantity	Honey from traditional hives tends to be mixed with the brood which usually attracts a lower price at market. Also, excessive smoke use to calm the bees can lead to a smokey flavour to the honey which reduces value. Due to the size constraint of most hollowed out logs harvesting size is usually limited to 5-7kgs.	Honey is 'pure' and without brood as you only harvest honey from the honey chamber, leaving the brood chamber undisturbed. Less smoke makes sure the honey tastes natural and this honey gathers top price at market. The larger chamber of the KTBH hives means harvests can be as much as 5-15kgs.	Honey is pure without brood and, if spun out of the comb, is free of wax too. Langstroth hives usually produce much more honey than either traditional or KTBH hives due to the size of both the brood chamber and super boxes. Full hives can weigh as much as 50kgs and honey harvests can be as much as 10-20kgs.
Effectiveness against elephants	Effective against elephants. See King <i>et al.</i> , (2007) for trial results.	Effective against elephants. See King, (2010) for trial results.	Research on the effectiveness of Langstroths in beehive fences is yet to be published.

# Beehive Fences using Traditional Hives

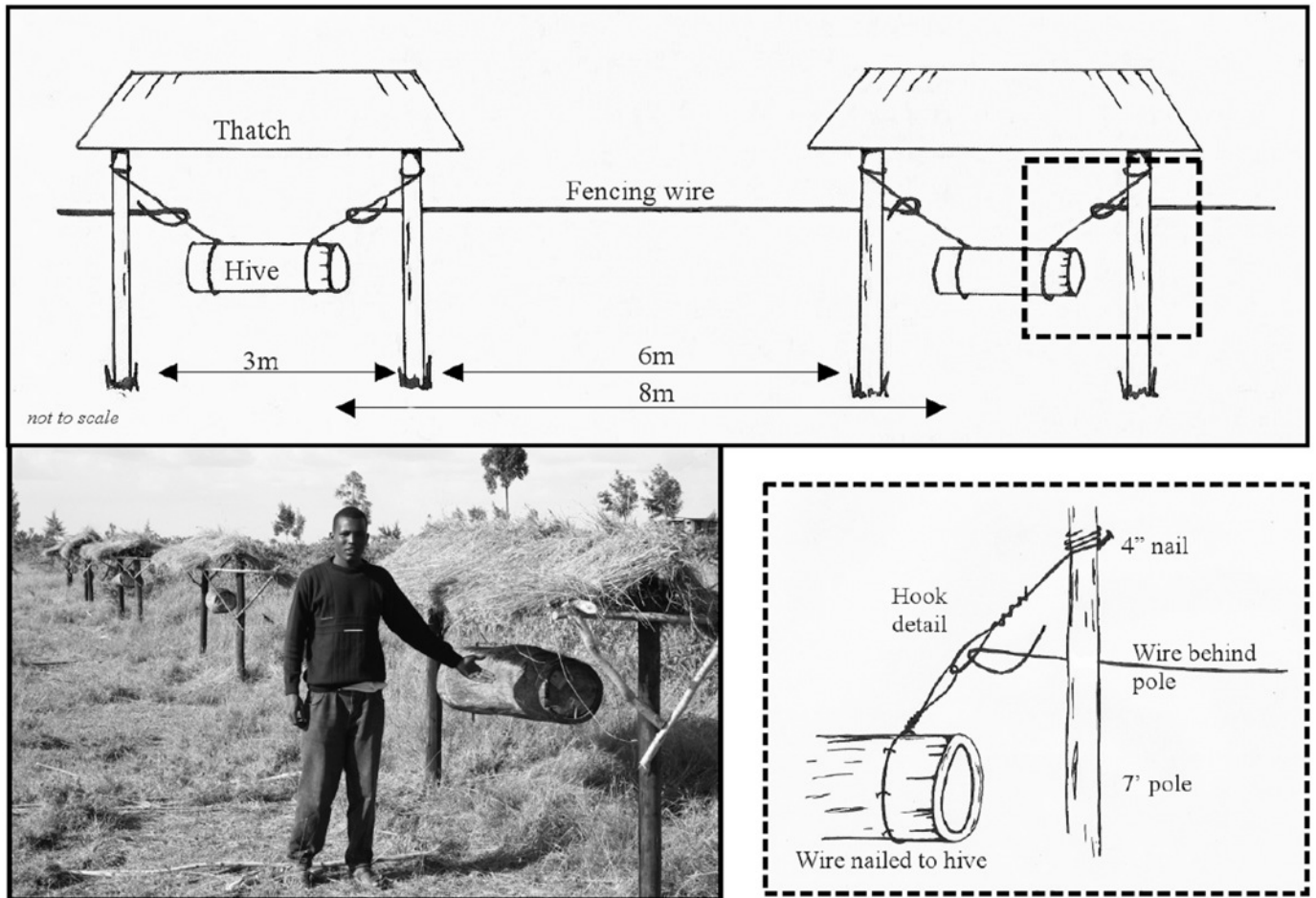

## Beehut design - the key element of the traditional beehive fence

This traditional log beehive fence was tested in Laikipia, Kenya in 2007 using traditional log beehives hung under small thatched roofs. Some of the log hives were bought from Tharaka, Meru at a cost of US\$4-6 per hive and others were found in the local area and moved into the beehive fence at no cost.

The beehut posts in this trial were spaced 6m apart allowing the hives to be spaced 8m apart. The beehives should be able to swing freely, suspended only by tightly secured fencing wire to the top of the posts. Each hive should be linked to each other with strong, taut, fencing wire that hooks to the centre of the permanent wire of each hive and must be, crucially, behind the upright posts on the crop side of the fence. An intruding elephant trying to enter the field will avoid the complex solid structure of the beehuts and will be channelled

between them. As the elephant tries to push through the thigh-high wire it causes the attached beehives to swing violently, thereby disturbing and releasing the bees to irritate or sting the elephant. However, if forced, the interlinking wire will break away before the beehive is pulled down. This also prevents elephants being trapped inside the farm as they can break out without damaging the hives. To prevent honey badger attacks nail a 70cm strip of iron sheet half way up the wooden post.

This style of beehive fence is ideal if you already own traditional log beehives as the cost of construction will be minimal. You may want to adopt a simpler roofing style as illustrated further on in this manual in the Kenyan Top Bar Hive section. Our latest research has shown that beehives can be placed 10m apart and still be effective so do try this to get a longer fence line.

# Beehive Fences using Kenyan Top Bar Hives

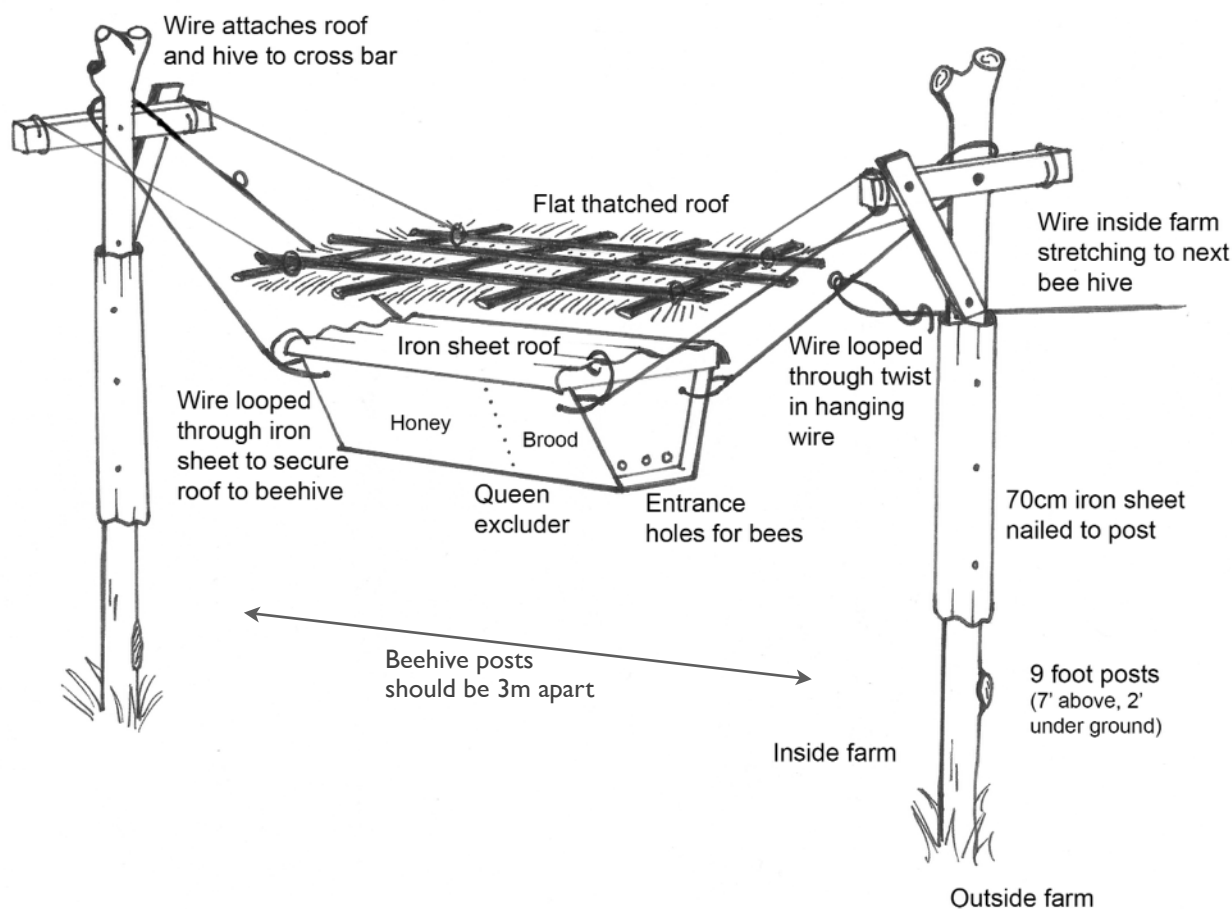

## Beehut design - the key element of the KTBH beehive fence

This beehive fence is comprised of two elements, the 'bee hut' and the connecting wire linking one beehive to the next with a gap of 7m between the post of one bee hut and the next. The beehut houses an 80cm long Kenyan Top Bar Hive constructed out of 9mm plywood and designed so that three beehives can be made from one large 2.4x1.8m industrial plywood sheet. The design of the KTBH hive (adapted from Jones, 1999) incorporates a queen excluder to keep the brood separate from the honey chamber; this increases the ease of harvesting and the value of the honey. The rain-proof roof is made from a corrugated iron sheet and is protected from the sun by a flat-thatched roof. The roof is hung by thin binding wire, too thin for honey badgers to crawl down should they succeed in bridging the protective 70cm iron sheets nailed to the posts. The 9 foot posts must be coated in a cheap oil-based insecticide to prevent termites.

The hive is hung by drilling small holes in the side walls of the hive and feeding through stronger plain wire. This is looped easily around the top of the upright posts and once through the hive the ends can be secured to the roof by drilling a small nail size hole in the iron roof to prevent wind blowing away the roof. A simple twist of the hive's hanging wire on the farm side of the beehut enables a strong piece of plain wire to attach one beehive to the next beehive 10 meters away. Should an elephant attempt to enter the farm he will instinctively try to pass between the beehuts and as the wire stretches the pressure on the beehives will cause them to swing erratically and, if occupied, release the bees. The wire is only looped through the hoop, not twisted tightly back onto itself, so that excessive pressure from an elephant will release the wire rather than pulling down the hive.



# Step by Step Construction of KTBH hives

Construction of the beehive fences using Kenyan Top Bar Hives is easy and following these simple steps will help ensure that your beehive fence is constructed correctly with an optimum chance of occupation by bees.

## I. Plywood Preparation



The ideal wood to use for the body of Kenyan Top Bar Hives is 9mm plywood as it can be sawed quickly and nailed easily into the shapes needed. Standard 9mm plywood usually comes in 2.4m x 1.2m sheets and you will find that three 80cm long beehives can be made from 1 sheet of plywood. Follow the dimensions below to cut out each side of the beehive. If plywood is not available any wood can be nailed together to make top bar beehives so long as it is not warped. The length and width of the beehive can be made to suit your budgets and resources.

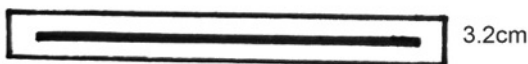
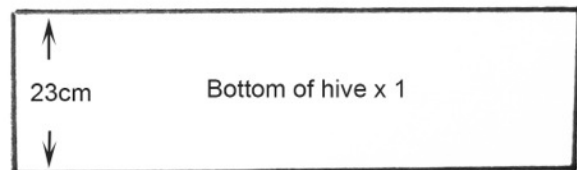
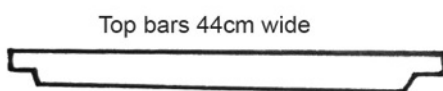
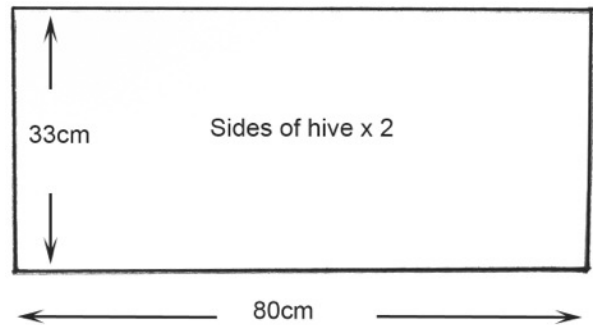
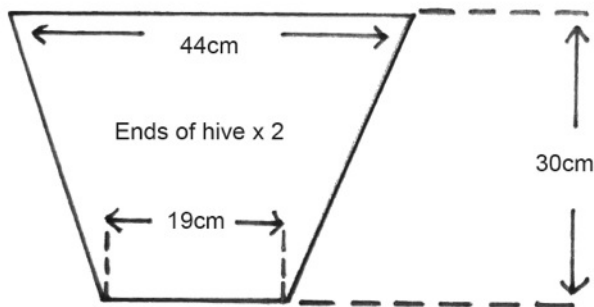

The 44cm long top bars should be cut from strips of natural wood, cedar or grevaria are both good choices. The only critical measurement is that the top bars must be 3.2m wide. Either grooves or points can be carved to encourage the bees to lay down wax.

Groove



V Point



This beehive design is adopted and adapted from Jones (1999) "Beekeeping as a business".

*Top Tip: Draw all pieces of the design onto the plywood sheet like a jigsaw before starting to cut. This ensures you get the most value out of each sheet. Keep all cut offs as they will help you later for internal structural additions.*

## 2. Construction of KTBH beehive



Before you glue and nail the pieces of plywood together, sand down the edges to ensure a smooth surface and to prevent getting splinters while you work. Using simple wood glue to seal the pieces of plywood together will help prevent ants and insects from crawling into the hive. Once glued, nail the pieces of the beehive together using plenty of 1 inch nails.

For the front end of the hive, nail the plywood front piece 2cm back into the hive leaving a small lip at the front. This gives the bees a place to rest or pause at the entrance to the hive.

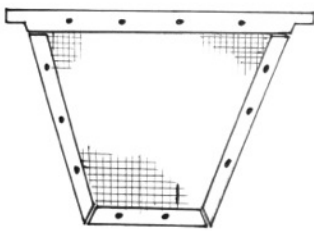

Coffee wire has small enough holes to prevent the queen from entering the honey section of the hive.

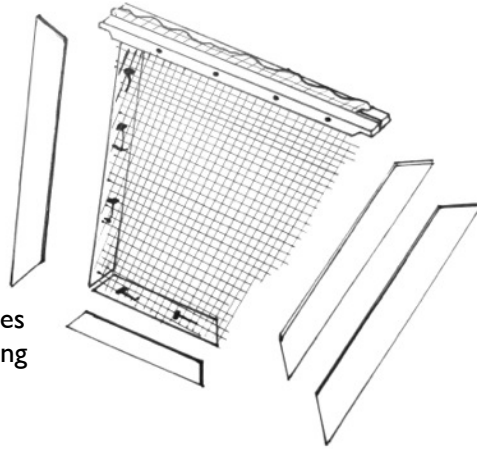

## 3. Queen Excluder

Saw one top bar in half (long ways) and nail a piece of coffee wire in between the two halves. Using either top bar wood or small strips of left over plywood, fashion the remaining structure of the queen excluder to fit the inside of the tapered beehive. The coffee wire should be tightly nailed between the wooden strips and should fit snugly inside the beehive.

## 4. Fitting the Queen Excluder

The queen excluder should be held in place six top bars back from the entrance of the hive. Thin strips of left over plywood should be nailed length-ways down the side of the hive leaving a 3.2cm gap for the queen excluder to slide into place. Ideally the queen excluder should be removable but you may need a small nail to hold it in place flush against the bottom and sides of the hive. The long strips of wood will become a ledge enabling the top bars to sit neatly inside the hive.

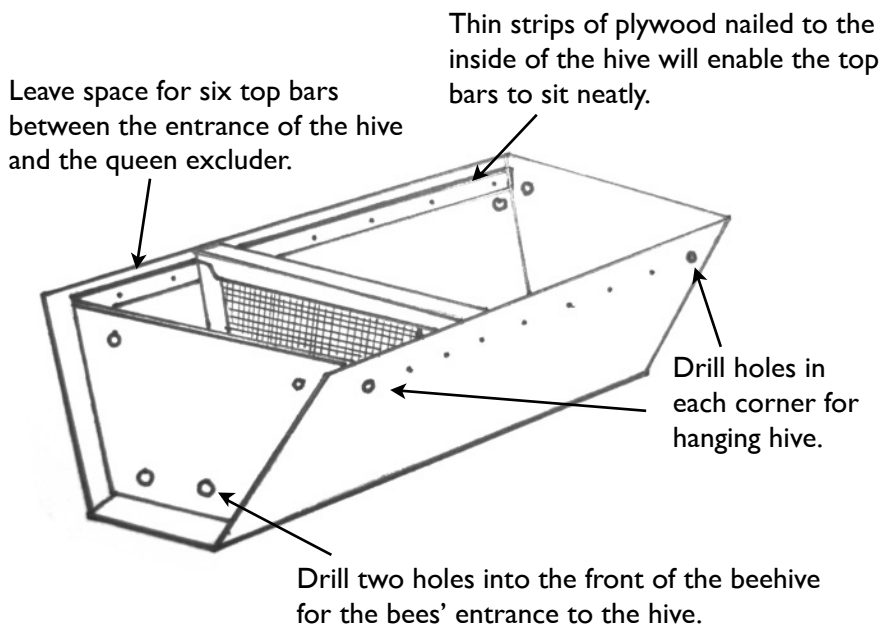

*Top Tip: At this stage its a good idea to varnish the outside of the beehives with a non-insecticide based varnish. Use varnish with a polyurethrene base as this is non-poisonous to the bees and will protect the hives from weathering. The sweet smell also appears to attract scouting bees.*

## 5. Top Bars and Roof



The top bars are the only part of the beehive that has to be accurately measured. The bars need to be exactly 3.2cm wide which is the proven distance apart that bees like to make their comb. This includes a small gap that the bees leave which helps them to pass between combs to both deposit wax and feed the brood. You may find it worth the investment to get these thin strips of top bars cut with an industrial saw machine. If you don't manage to cut the top bars exactly to 3.2cm the bees tend to lay down their wax combs over the join of the top bars. This isn't a disaster, it just means that you'll find it harder to harvest honey as several top bars will get 'stuck together'.

The top bars should fit tightly together across the top of the beehive.

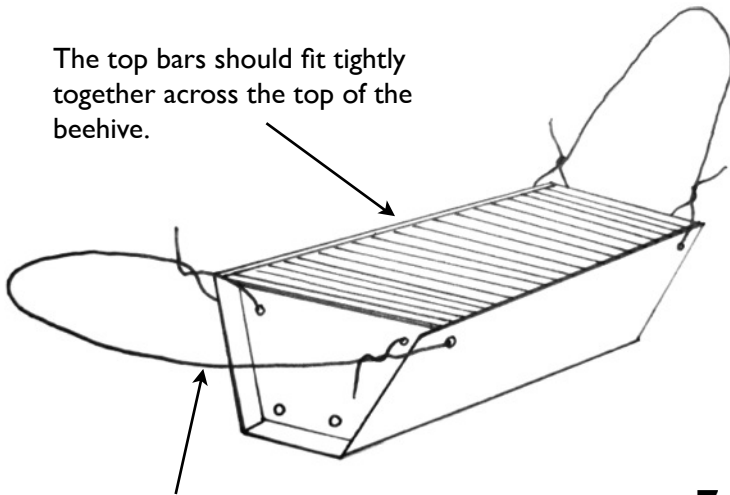

Strong wire should be looped through previously drilled holes ready for hanging.

## 6. Sealing the hive

Fitting the top bars into the hive should create a sealed chamber beneath. This will help you during harvesting, as bees should only be able to escape from the top bar gap that you lift out. If you have spare wood you can cut and place a flat piece of plywood over the top of the top bars to create a 'lid' but its not essential.

## 7. The Roof

A waterproof roof is essential to keep the bees dry. Corrugated iron sheets are ideal for this as the water flows off the roof and away from the hive. You need to make the roof wider and longer than the hive so that the hive is totally protected from the rain. If you buy 3x1m iron sheets you can roof 4.5 beehives if you cut each roof sheet into 1m x 65cm strips.

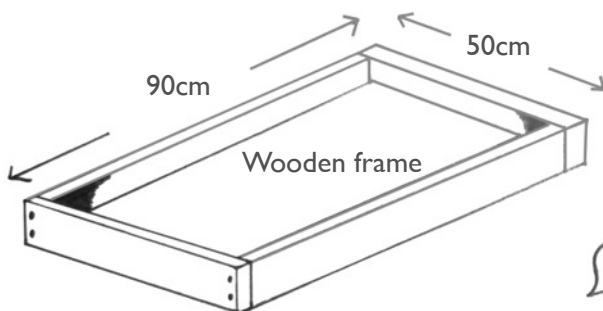

Holes for attaching to hive with ends of hanging wire.

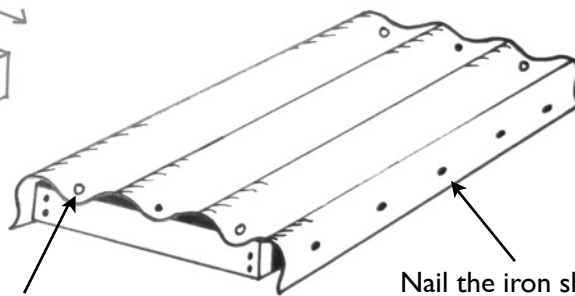

Nail the iron sheets firmly to the sides and top of the wooden frame.

**Top Tip:** Drill two holes into the front of the iron sheet to allow the ends of the hanging wire to loop through and tie the roof to the beehive. This stops the roof flying off in strong winds and helps stop monkeys or honey badgers from accessing the beehive. Hammering a 4 inch nail through the iron sheet creates a perfect hole.

# Beehive Fences using Langstroth Hives



## Langstroth Hive Design

Langstroth beehives are made of rectangular or square boxes that fit snugly one on top of the other. The larger brood chamber on the bottom contains a set of frames usually containing a thin foundation strip of beeswax that is held in place with fine strips of wire. Once the bees have occupied the brood chamber, and built up the foundation combs with beeswax and brood, a second 'super' box should be placed on top. In between the two boxes lies a queen excluder wire mesh that lies as a horizontal sheet over the top of the brood chamber combs. This prevents the queen from travelling up into the super box which allows the worker bees to fill the super with pure wax comb and honey stores. This is the section that you harvest for honey leaving the brood chamber alone.



A super on top of a queen excluder and brood box, held in place with a wire

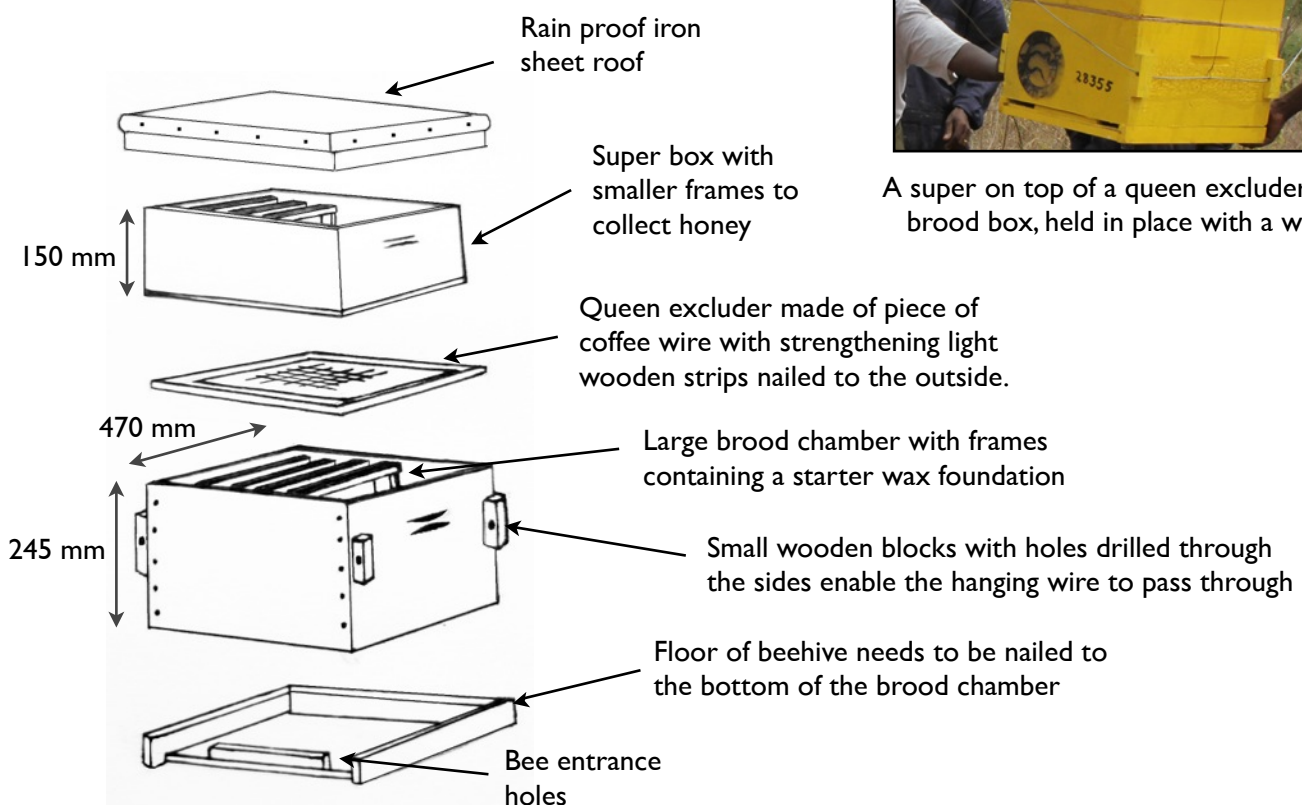

# Constructing the beehive fence



## 1. Measuring field for posts

The posts between each beehut should be 7m apart. The second post for hanging the beehive should be 3m apart. Therefore you need one beehive for every 10m of farm boundary. This distance apart is taken from an observation that elephants won't walk within 4m of active beehives. Should an elephant try to push between the beehuts he will be less than 4m from the beehives on either side of him. You must construct your beehive fence on the *outside* of your farm so it is the *first* object that approaching elephants see. There is some evidence they recognise the shape of beehives and will avoid them on sight. Leave any other fence barriers you have in place.



## 2. Painting posts with insecticide

The wooden posts should ideally be 8 or 9 foot long and need to be treated with an insecticide from top to bottom and left to dry thoroughly before embedding into the ground. If you can't afford an insecticide, painting the posts with old engine oil is a good alternative. Straight timber posts from a commercial timber yard that use renewable plantations is the next best option. If you have plenty of trees around your farm, use a coppicing technique to cut strong branches rather than cutting down whole trees. Some *Comiphora* tree species will re-grow roots creating a live bio-fence to hang your beehives from, do not paint oil on these live tree posts.



## 3. Digging holes

The posts need to be embedded approximately 2.5 foot into the ground. A simple measuring tool is to ensure the hole is at least as deep as the length of your arm from finger tip to armpit. It is essential to hammer in stones around the base of the post and to pack in the soil as tightly as possible when erecting the posts. A weak post will simply topple over in heavy rain or when the hive is heavy with honey making the hive vulnerable to honey badgers. Do not be lazy with digging a deep hole, shallow holes mean the posts will quickly topple inwards when the beehive is heavy with honey.



## 4. Hanging the hives

Once the posts are firmly embedded in the ground you can nail a small piece of rough wood or a branch as a cross bar to help hold up both the beehive and thatched roof. Strong 4 inch nails are ideal for this as there will be quite some weight hanging on this cross bar. 70cm of iron sheeting needs to be nailed to the upright post at least 2 feet off the ground to prevent honey badgers from climbing up the posts. The hive should be hung at chest height for ease of harvesting, to prevent honey badgers leaping up from the ground, and to be as visible as possible for an approaching elephant.

## 5. Thatching the Beehive Fence



The iron sheet roof will keep the bees dry in the rain but if left in the sun the hive will overheat and the bees will become aggressive and leave. A simple thatched roof is an easy solution to keep the hive cool from the sun. It also creates another swinging moveable element to the beehive fence which further disturbs elephants trying to enter a beehive fence protected farm. A lattice shape made out of sticks creates a strong base for the thatched roof. Sandwiching the grass between two lattice work frames will stop the grass from blowing away in strong winds. The sticks should be held together with small twists of binding wire. Use plenty of crossed sticks and plenty of grass to make a good thick roof.

## 6. Wiring together the Beehive Fence



The thatched roof should hang freely a foot above the hive for clear air circulation and to remove the iron sheet roof easily when it comes time to harvest the honey. Hang the roof by twisting simple binding wire to each corner of the thatched lattice work and loop this round the cross bar on the post. This system makes it easier to lift the roof should it sag down onto the beehive over time. Each beehive in the fence should be linked to each other with a strong piece of plain wire which should loop through the wire hanging the beehive and, crucially, must be on the inside of the farm so the beehives will swing should an elephant try to enter the farm. Keep the wire high (at least chest height) so cows, goats and dogs can pass safely underneath.

The author standing next to a stretch of beehive fence constructed before the planting season in the community of Sagalla, just outside of Tsavo East National Park, Kenya.



*Top Tip: Paint numbers onto the beehives after they have been hung on the fenceline. Numbers help to keep accurate records of occupation and honey harvesting events and are a small deterrent to potential thieves. Painting on letters help to identify which beehive belongs to which farmer and is a theft deterrent.*

# Using “dummy hives” in your beehive fence

The beehive fence design requires hanging a beehive every 10 meters to create a strong barrier to invading elephants. If you spread the beehives any further apart than 10 meters, the wire can sag, the elephants might walk over it and the fence becomes less effective. To protect the boundary of 1 acre of farm land you therefore need 24 beehives, quite expensive for some farmers to afford and also quite demanding in terms of occupancy rates for the density of bees in semi-arid areas. We have successfully tried installing “dummy” beehives *every other* beehut and can recommend this design if you have few beehives or a big farm boundary that needs protection. We recommend 2.4m x 1.2m block board or 9mm plywood sheets for cutting out dummy’s in the silhouette of a beehive. Shapes reflecting either KTBH or Langstroth are possible and a design for getting the most number of KTBH dummy hives out of a piece of block board is illustrated below.

Cutting out 12 Dummy Beehives on Block Board Sheets

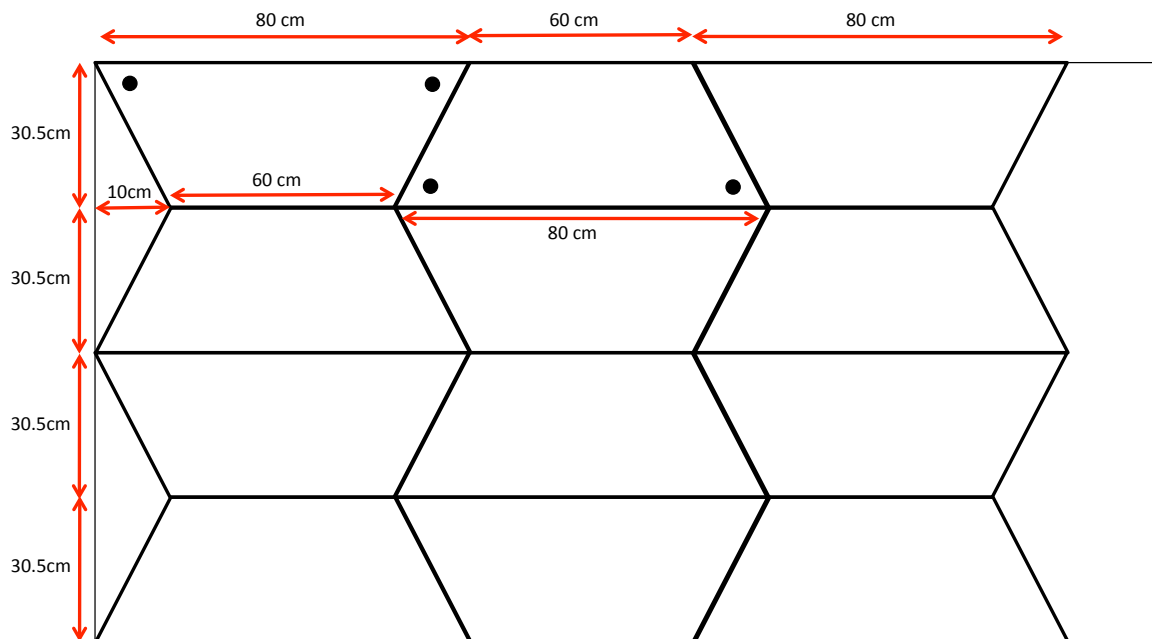

A 240m beehive fence consisting of 12 beehives and 12 “dummy” beehives can protect 1 acre of farm land. This is a good design if you live in a dry area, bees are scarce, or if you cannot afford so many hives.

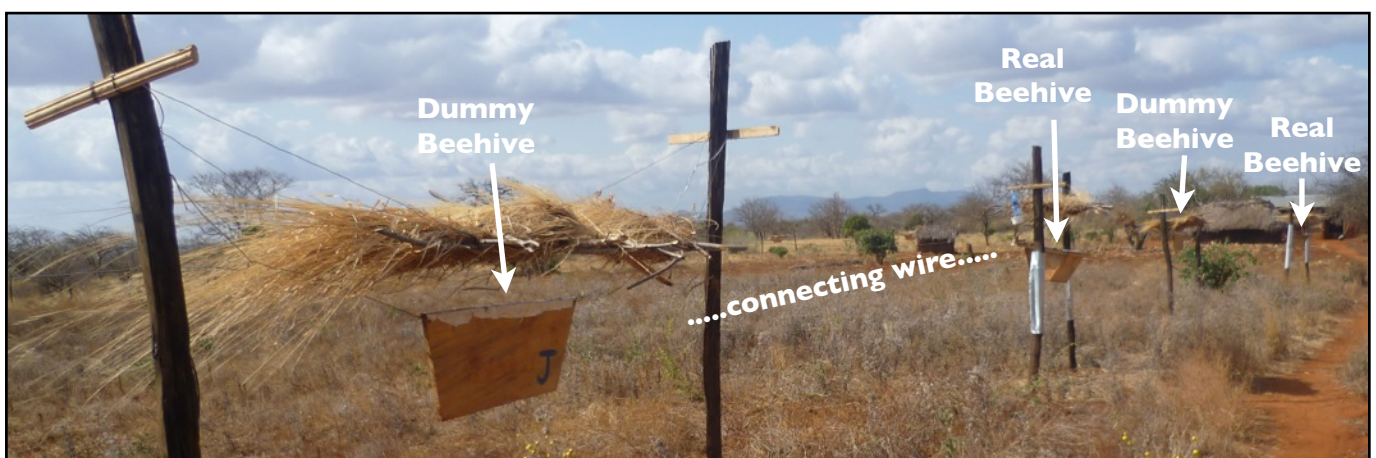

**Top Tip:** Don't forget to maintain the “dummy” thatched roofs - its important that they look and swing the same as the real beehive units. Paint or varnish the dummy beehives as water getting in between the plywood will cause the wood to split after a few rainy seasons.

# Common Issues & Maintenance Tips



## Post maintenance & low beehives

As the beehives get heavy with honey OR if there has been heavy rainfall, the posts can start to lean in towards the beehive. As the beehive gets low to the ground (less than 1.2m), it becomes vulnerable to predators such as honey badgers or mongoose who can leap up to grab the bottom of the hive. Posts should either be replaced or dug back into the soil using stones and rocks embedded into the soil to keep them upright. If all else fails, consider connecting a 3rd post along the top - keeping the two upright posts apart.



## Live Posts - Bio-fence to hang beehives

Certain *Comiphorer* tree species can be cut for posts and, if given a day or two to rest after cutting, can be replanted as both a post and as a tree. Once the roots have started to grow again, shoots and leaves will start to grow providing natural shade for the beehives in the future. The roots will help to keep the post strong for carrying the beehives and will create a “bio-fence” that should require very little maintenance. However, *do not* hammer nails into the post or it will kill the tree - try wiring honey badger deterrents like iron sheets to the trunk instead.



## Water & Feeding of Bees in Dry Season

As the dry season approaches the bees will come under stress as the natural water and abundant nectar in the flowering plants start to dry up. It is essential to provide clean water for the bees throughout the dry season. If the bees have enough water they can usually survive a 3 month dry period. If you see any signs of agitation or swarming behaviour start to feed the bees with a mixture of sugar and water (40:60 ratio) to keep them in your hive. This can be placed either inside the hive OR at a convenient location hung in a nearby tree. One cup of water every few days should make sure your bees survive the dry season and they will start to produce honey again as soon as rains arrive and flowering plants bloom.



## Clean empty beehives regularly

It can take some months for all your beehives to be occupied with bees, particularly if they are new beehives and have no smell of honey and old wax inside. Empty beehives provide a perfect home for many bugs, beetles, wasps, moths, lizards and potentially some snakes. No bees will come and make a home in a beehive if such creatures are living in there. It is essential to open any empty beehives at least every month to clean them and clear out any unwanted guests. Remember to remove these creatures some distance away or they will simply climb back into the hive again.



# Honey Harvesting



## Protective clothing

Disturbing a beehive to harvest honey will trigger the bees to attack. To minimise disturbance: work quietly, only lift one top bar out at a time and use smoke to calm the bees. Additionally cover exposed skin to prevent stings. Wearing a beekeeping suit is ideal as they are designed to keep bees away from your skin. A wire mesh hat is ideal, but can also easily be made from cutting open an old flour sack and sewing mosquito netting across the opening. Cover your arms with a shirt, or blanket and wear gloves and shoes.



## Smoking the hive

As you lift the roof off the beehive its helpful to puff some smoke over the top bar hives for a minute or two. The smoke will cause the bees to consume some of their honey and this slows them down and makes them easier to handle. As you lift each top bar out, smoke the bees gently to stop them becoming aggressive. A smoker can be bought from any beekeeping supply shop but you can also make your own. A good smoking material is old hessian sacks, dry elephant dung and dry twigs. Make sure you don't direct a lit flame towards the hive or you could burn the bees.



## Honeycomb

Harvesting from the honey chamber of a hive (*don't harvest the brood chamber*) will provide you with sheets of pure wax comb filled with nothing but delicious honey. Selling the honey in comb is very desirable and fetches a high price as you can eat both the comb with honey. If you prefer pure honey, cut the honey comb into a bucket lined with a simple mesh material. Any fabric with small holes in will do to help drain the honey from the comb. Either leave the honeycomb overnight to drain or squeeze the comb to release the honey. The left over wax is also a valuable to make candles.



## Elephant Friendly Honey

Honey harvested from beehive fences has been coined as 'Elephant-Friendly Honey'. The elephants are deterred from entering farms during their natural foraging activities ensuring that farmers are less disturbed by elephants and, we hope, will become more tolerant of elephants walking near their farmland. Simple labels can be made for honey jars to advertise the unique source of the honey and this will attract interest and support for more beehive fence projects. Keep a record of how many kilos of honey is taken from each hive.

## Beekeeping and Honey Harvesting Advice

Although we do not go into all the steps of harvesting honey here in this manual, there are ample free beekeeping resources online (see page 18 for links) and many more excellent books on beekeeping skills that can be bought in any text book center.

# Hive Occupation Records

The table below should help you to design your own record sheets for monitoring activity around your beehive fence. Keep a record of every event including colony occupations, abandonment events, new occupations, harvesting events, visits by elephants or honey badgers etc. This system will help you identify sections of the beehive fence which are vulnerable to predation, drought, disturbance and which sections are providing you with the best honey harvests.

Beehive	Hang date	Occupied date	Abandoned date & reason	Harvesting date & kilos	Event	Event	Event
A1 (example)	6.2.2010	18.4.2010	12.10.10 (left due to drought)	1.8.2010 6kgs	Occupied 8.1.2011	3.2.2011 visit by elephants but no break through	etc
A2	6.2.2010	9.4.2010		7.7.11 4kgs	occupied 15.4.11	harvested 7.5.12 8kgs	etc
A3							

**A Beehive Fence in action...**

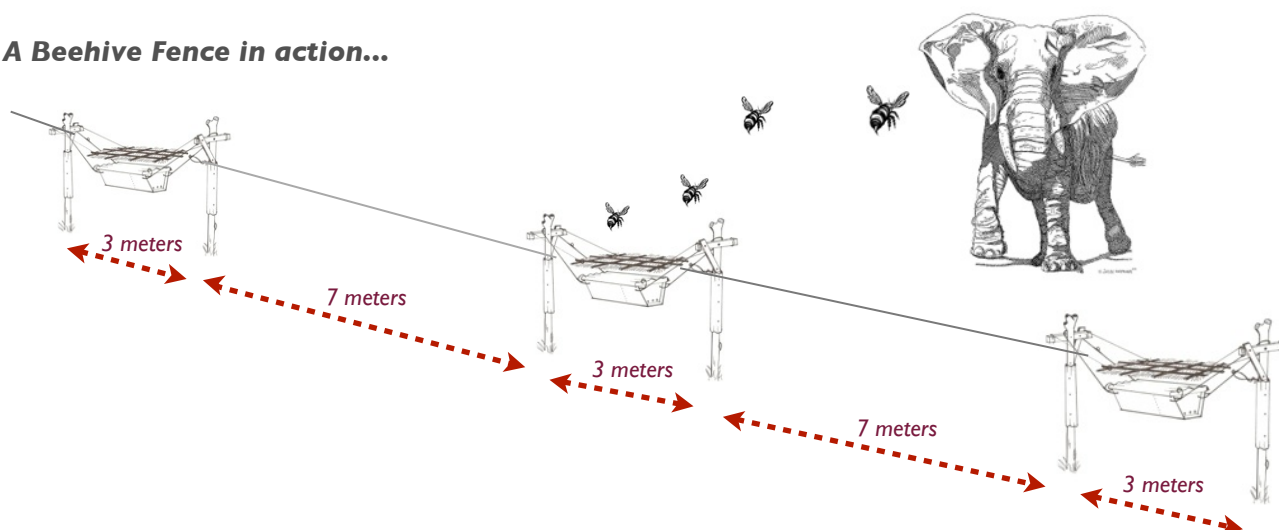

## Top Tips to increase hive occupation from your Beehive Fence

- ☑ Plant flowering plants or crops around your beehive fence to provide nectar and pollen for the bees. Do not cut down any indigenous flowering plants as well fed bees will provide you with lots of honey. Sunflowers are ideal plants as, if pressed, they can also provide you with sunflower oil for cooking.
- ☑ Rub beeswax onto the middle of your KTBH top bars to help the bees find the hive and to start building wax along the top bars. Rubbing propolis around the hive entrance may also attract passing bees.
- ☑ When providing water for the bees, make sure you place stones or sturdy branches in the water as bees will drown in deep water. Replace any stagnant or green water as it can poison the bees.
- ☑ If thatching grass is in short supply, use multiple sticks to form a dense stick roof - keeping the bees cool is absolutely essential or they will become aggressive and will eventually swarm and leave the hive.
- ☑ Cut down any long grasses or branches that overhang or touch the beehives, these will provide bridges for ants to crawl into the hive or for pirate wasps to attack the bees.

# Elephant Movement Records

Elephants will continue to visit beehive fence protected farms, most probably due to a memory of available crops from previous years. Most farmers sleep in their farm next to their crops building up to harvest season and its likely that farmers with new beehive fences will continue to sleep in the farm to check that the system is working. If possible, farmers should try to resist scaring away the elephants as they approach the farm. Trust the beehive fences to stop the approaching group. Try to watch the behaviour of the elephants, how do they move around the fence? Are they approaching the wire or trying to push through between hives? If its too dark to see clearly, make a note of the footprints the next morning. I highly recommend keeping a record and notes of this behaviour for the first few seasons using a beehive fence. Patterns of behaviour may emerge including particularly aggressive movements that may lead to an individual trying to

break through the fence. The ideal situation is to avoid direct conflict with elephants to reduce the risk of either you or the elephants coming to harm. If you manage to reduce direct action (stone throwing, firecrackers, shouting etc) to a minimum it will mean the elephants will become less habituated to these more direct action attempts and they should respond and run away should you need to resort to these tactics later in the season. Additionally, keeping a record of where elephants have approached the beehive fence (or attempted to enter) will help to focus multiple deterrent tactics in that area of your farm. You may want to try covering the linking wire with chilli oil or hang cow bells to help warn you when an elephant is trying to break through.

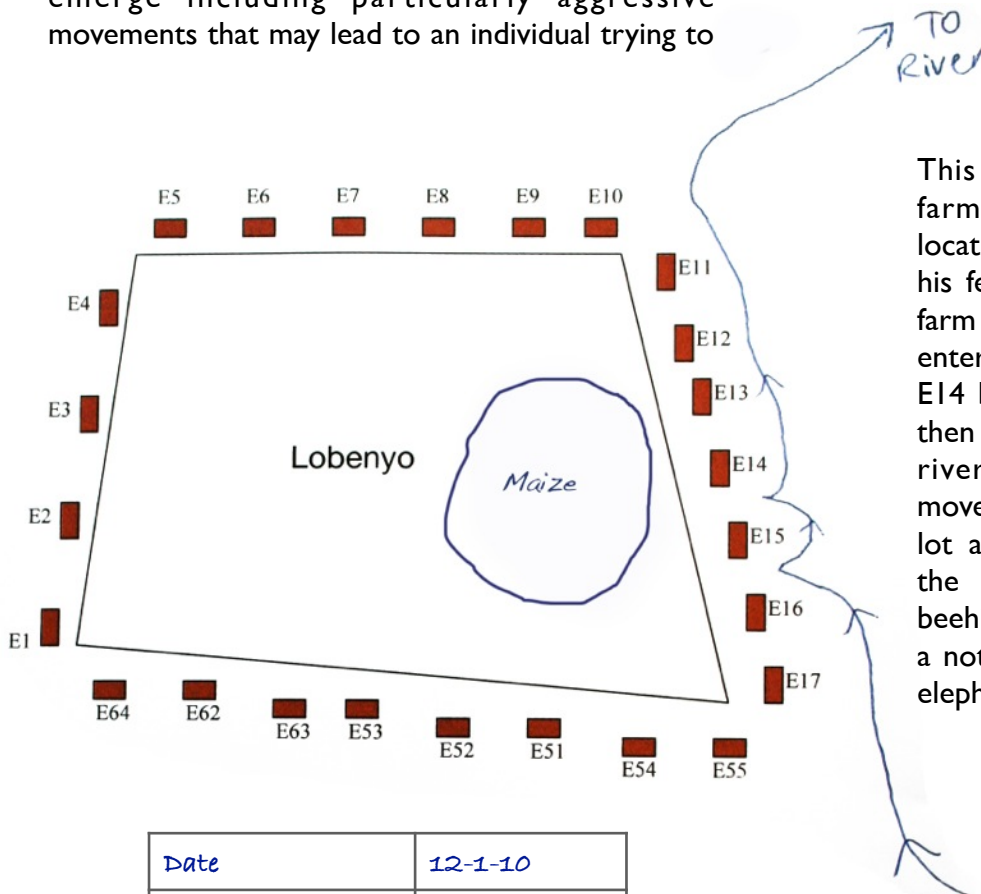

This monitoring sheet example of farmer Lobenyo's farm shows the location and number of each beehive in his fence. The elephants approached his farm at one corner and attempted to enter twice between hives E16, E15 and E14 before walking along the fence and then finally giving up and heading to the river instead. By drawing on the movements of these bulls we can learn a lot about how the elephants approach the beehive fences and whether the beehive fence deterrent is working. Keep a note of the date, time and number of elephants in the approaching group.

Date	12-1-10
Time of Incident	Night
No. of Elephants	3 bulls
Enter Farm?	No

# Predicted Conditions for Success

The table below summarises the predicted conditions for success of beehive fences when deploying beehive fences in Kenya as an elephant deterrent in locations where the African savannah elephant *Loxodonta africana africana* resides alongside farmland. The greatest chances of success may be found where a farmer, living below 2,500m, owns his own KTBH beehives and places them in a circular position around his farm.

Higher Success	Lower Success
<p><b>Lower Altitudes</b></p> <ul style="list-style-type: none"> <li>• Between 400m – 1200m above sea level where <i>A. m. scutellata</i> typically lives should be most effective.</li> <li>• Coastal regions 0 - 400m where <i>A. m. litorea</i> lives is also known to be an aggressive honey bee so results should be comparable.</li> <li>• Warmer conditions at night keep bees active and capable of swarming out of the hive when disturbed.</li> </ul>	<p><b>Higher Altitudes</b></p> <ul style="list-style-type: none"> <li>• Above 2,500m lives <i>A.m.monticola</i>, which is a less aggressive honey bee and might have less affect when swarming out and disturbing elephants.</li> <li>• Cooler conditions means bees are less active at night when most crop-raiding occurs.</li> <li>• Snow or icy conditions may result in inactivity or semi-dormancy of bees where valuable honey stores are consumed to keep them warm and alive.</li> </ul>
<p><b>Farmer/Individual Owned Beehives</b></p> <ul style="list-style-type: none"> <li>• Will maintain fences due to personal financial incentive of selling and using honey and wax.</li> <li>• More likely to want to learn new beekeeping techniques and skills.</li> <li>• Vigilant on a daily basis for theft or elephant movements around bee fences.</li> </ul>	<p><b>Community/Group Owned Beehives</b></p> <ul style="list-style-type: none"> <li>• Confusion over who is responsible for maintaining each hive or each section of the beehive fence.</li> <li>• Lack of incentive for harvesting honey if proceeds are divided amongst many.</li> <li>• Less accountability for stolen honey or beehives.</li> <li>• Employment of hive technician recommended.</li> </ul>
<p><b>Small Circular Beehive Fences</b></p> <ul style="list-style-type: none"> <li>• Fully encloses each farm preventing elephants from walking around the ‘end of the line’ to enter the farm.</li> <li>• Leave an appropriate ‘gap’ around the house or access area to prevent accidental disturbance of the hives during the day.</li> <li>• Enables elephants to pass between farms on their natural migration routes.</li> </ul>	<p><b>Long Straight Lines of Beehive Fences</b></p> <ul style="list-style-type: none"> <li>• Applicable for communally run farms sitting side by side, but the farms at either end of the line will get crop raided more than the central farms.</li> <li>• Once inside a farm they can then have access to all the other farms ‘behind’ the beehive fence deterrent.</li> <li>• Extended beehive fences may have problems with maintenance as several farmers will need to co-operate to look after each section of the fence.</li> </ul>
<p><b>KTBH or Langstroth Hives</b></p> <ul style="list-style-type: none"> <li>• Swing well between posts.</li> <li>• Waterproof against rain.</li> <li>• Brood chamber keeps queen and brood separate from honey chamber making harvesting easier and the honey more valuable.</li> <li>• Easy to maintain.</li> <li>• More expensive to make but income from honey should justify initial outlay.</li> </ul>	<p><b>Traditional Log Beehives</b></p> <ul style="list-style-type: none"> <li>• Often already available locally so can be easily transferred to beehive fences <i>but</i> if not available means cutting down large valuable trees to make hives.</li> <li>• Brood and honey chambers are mixed so harvesting can result in destroying the combs and the bees will swarm and leave. However, nailing a circular piece of coffee wire inside the hive will act as a basic queen excluder.</li> <li>• Difficult access to honey can mean use of excessive smoke and lower quality honey due to smoky flavour.</li> </ul>

# The Science and Research behind this Manual

All our research papers and construction manuals can be downloaded for free from our project website  
[www.elephantsandbees.com](http://www.elephantsandbees.com)

1. **Soltis, J., King, L.E., Douglas-Hamilton, I., Vollrath, F. and Savage, A.** (2014) African Elephant Alarm Calls Distinguish between threats from Humans and Bees. *PLoS One* 9(2): e89403. doi:10.1371/journal.pone.0089403
2. **King, L.E.** (2013) Elephants and Bees. Could honey bees be effective for Asia's crop-raiding elephants? *Sanctuary Asia Magazine*, India. October 2013.
3. **King, L.E., Douglas-Hamilton, I, Vollrath, F.** (2011) Beehive fences as effective deterrents for crop-raiding elephants: field trials in northern Kenya. *African Journal of Ecology*. 49: 431-439.
4. **King, L.E.** (2010) The interaction between the African elephant (*Loxodonta africana africana*) and the African honey bee (*Apis mellifera scutellata*) and its potential application as an elephant deterrent. DPhil thesis. University of Oxford, UK.
5. **King, L.E., Soltis, J., Douglas-Hamilton, I., Savage, A. & Vollrath, F.** (2010) Bee threat elicits alarm call in African Elephants. *PLoS One* 5(4), e10346. doi:10.1371/journal.pone.0010346.
6. **King, L.E., Lawrence, A., Douglas-Hamilton, I. & Vollrath, F.** (2009) Beehive fence deters crop-raiding elephants. *African Journal of Ecology* 47, 131–137.
7. **King, L.** (2009) Bees help Protect Crops From Damage by Elephants in Kenya. *Bee Craft*. September P9-11.
8. **King, L.E., Douglas-Hamilton, I. & Vollrath, F.** (2007) African elephants run from the sound of disturbed bees. *Current Biology* 17, R832–R833.
9. **Vollrath, F. & Douglas-Hamilton, I.** (2002) African bees to control African elephants. *Naturwissenschaften* 89, 508–511.
10. **Jones, R.** (1999) *Beekeeping as a Business*. International Bee Research Association, Published by Commonwealth Secretariat, London.

## Helpful Websites and Resources:

Elephants and Bees Project - [www.elephantsandbees.com](http://www.elephantsandbees.com)

Save the Elephants - [www.savetheelephants.org](http://www.savetheelephants.org)

Bees for Development - [www.beesfordevelopment.org](http://www.beesfordevelopment.org)

Honey Care Africa - [www.honeycareafrica.org](http://www.honeycareafrica.org)

Natural Beekeeping Forum - [www.biobees.com](http://www.biobees.com)

Resources for African Beekeeping - [www.apiconsult.com](http://www.apiconsult.com)

International Bee Research Association - [www.ibra.com](http://www.ibra.com)

African Elephant Specialist Group - [www.afesg.com](http://www.afesg.com)



Download all scientific papers from  
[www.elephantsandbees.com](http://www.elephantsandbees.com)

# Save the Elephants



## *Mission*

*To secure a future for elephants and sustain the beauty and ecological integrity of the places they live, to promote man's delight in their intelligence and the diversity of their world, and to develop a tolerant relationship between the two species.*

## **Four Pillars: Research, Protection, Grassroots, Education**

The Save the Elephants charity was founded in 1993 by Dr. Iain Douglas-Hamilton, OBE, Chief Executive Officer of STE, who made a pioneering study of elephant behaviour in the late '60s in Lake Manyara National Park, Tanzania, and has worked on elephant status Africa-wide since. Explorers, conservationists and elephant scientists serve as fellow trustees or advisors to the board.

We focus on research, education, grass-roots conservation, monitoring and protection and are involved in projects across Africa: Kenya, Democratic Republic of Congo, Gabon, South Africa, Mali and now China. Research projects range from investigations into the dynamics of elephant society at a molecular level through to ranging behaviour of savannah, forest and desert elephants using high-tech Global Positioning System collars. We are at the forefront of developing technology to track and interpret elephant movements, providing vital information for land-use management plans aimed at reducing conflict with humans whilst allowing elephants continued access to vital parts of their range.

Save the Elephants works closely with government and non-governmental organisations, universities and research institutions to ensure the long-term conservation of elephants in Africa. This requires a multifaceted approach and our activities cover research, conservation, community education and training, and public awareness at both a national and international level. We are involved in surveys to establish population trends, elephant mortality and ivory trade, providing systematic and factual information used by CITES (Convention on the International Trade in Endangered Species) to ascertain the conservation status of the African elephant. We recognise the need to find solutions to reconcile elephants with the people with whom they share their land and our Elephants and Bees Project is core to our mission to investigate innovative and cost-effective methods to reduce conflict as well as exploring the cultural relationships between people and elephants.

Please see [www.savetheelephants.org](http://www.savetheelephants.org) for more details on STE's overall organisation's program.



**Dr Lucy E. King** has been researching the use of bees as a natural elephant deterrent since 2006 and has published her findings in numerous scientific journals. Her research has won her *The St Andrews Prize for the Environment 2013*, *The Future for Nature Award 2013*, and *The 2011 Thesis Award* from UNEP/CMS for her Doctor of Philosophy thesis conferred by the University of Oxford in 2010. Previously, she completed an MSc in Biology, Integrative Bioscience, from Balliol College, Oxford (2006) and gained a First Class BSc degree in Zoology from Bristol University (1999). She was brought up in Somalia, Lesotho, Kenya and England, but now lives in Nairobi leading further research into the use of bees as an elephant deterrent both in Kenya and further afield.

### **Author's note - Beehive fence community**

If you have been inspired by this beehive fence construction manual and plan to initiate a project around your farm I would encourage you to contact me and share your experiences and outputs. Any anecdotes or suggested improvements of the design of the beehive fences will help future farmers wanting to try the idea. By combining data and success rates from different beehive fence protected farms we can work towards improving the concept year after year. Please email me at [lucy@savetheelephants.org](mailto:lucy@savetheelephants.org) and I will be happy to offer any advice on your plans.



**Acknowledgements** I thank the Office of the President of Kenya and Kenya Wildlife Service for permission to conduct this research in Kenya. I am grateful for the significant contributions to the science behind this manual from my colleagues Dr Iain Douglas-Hamilton, Professor Fritz Vollrath, Dr Joseph Soltis, Dr Anne Savage, Dr Anna Lawrence, Onesmas Kahindi, Lucas Lepuiyapui and Wilson Lelukumani.



We are grateful for the co-operation and hospitality shown by all the communities of Chumviyere, Etorro, Sagalla and Ex-Erok. Funding for this research gratefully received from ESRC/NERC, Disney Worldwide Conservation Fund, The Rufford Foundation, Rufford Small Grants Foundation, Future for Nature, St Andrews Prize for the Environment, Bella MATATA, VSNi, The James Ford Bell Foundation, Appropriate Development Consultancy Ltd, The Kileva Foundation, Balliol College Oxford, and Save the Elephants. Disney Worldwide Conservation Fund supported the production and printing of this manual.



Beehive Fence Construction Manual

Copyright © Dr Lucy E. King

Third Edition 2014

All rights reserved

Published by

The Elephants and Bees Project

Save the Elephants

P.O. Box 54667

Nairobi 00200

Kenya

Project website: [www.elephantsandbees.com](http://www.elephantsandbees.com)

Email: [lucy@savetheelephants.org](mailto:lucy@savetheelephants.org)